

# Diesel Transfer Pump User Manual



Read Carefully Before Use  
Keep for Future Reference

# Safety Information

## **DANGER!**

- Read this manual before use and keep for future reference. Ensure any person who will use this device reads this manual, particularly its safety information, and include it with the device if it is ever sold or given away to a third party.
- **ONLY** use this device in accordance with these instructions and all applicable local and national laws. Only use it for its intended purpose, transferring diesel fuel. Failure to do so may result in serious property damage and severe personal injury, possibly including death.
- Diesel and its fumes are potentially flammable. Keep away from open flames and any other sources of heat or electric sparks.
- **NEVER** smoke or use any form of electronics—including telephones & electronic tablets—around this device while it is in use.
- **ALWAYS** electrically ground any container diesel is being transferred into or out of before beginning work.
- **ALWAYS** wear personal protective equipment (PPE) sufficient for your task, generally including ANSI-approved vision and breathing protection and gloves.

Diesel is highly toxic and even small amounts are fatal to children. If it is ingested or its vapors inhaled, contact Emergency Services or Poison Control immediately and seek medical advice and attention. Clean away any diesel on the skin with soap but **DO NOT** induce vomiting.

- **NEVER** allow children to use this device. Only allow use by persons with impaired mental or physical abilities under close and constant supervision.
- **ALWAYS** ensure the work area around this device and your fuel containers has adequate ventilation.
- **ALWAYS** monitor the flow rate and fill levels in your containers to prevent spills and other accidents.
- **ALWAYS** empty the device after each use. Clean up any leaked or spilled fuel immediately.
- **DO NOT** modify this device, except to check for loose fittings and connections prior to use and tightening them as necessary. If any connection is damaged so that a leak would be unavoidable, cease use immediately and repair or replace such damaged parts before any further use.

# Specifications

<b>Material</b>		AISI 1045 Steel, 3A Steel, PVC	
<b>Dimensions</b>		8.5×5.7×6.1 in.	21.5×14.5×15.5 cm
<b>Inlet &amp; Outlet Thread Size</b>		¾ in. NPT	25 mm
<b>Input Power</b>		12V DC	
<b>Max. Speed</b>		3600 rpm	
<b>Duty Cycle</b>		30 min./hr.	
<b>Rated Power</b>		0.2 hp	175 W
<b>Flow Rate</b>		11.9 gpm	45 L/min.
<b>Lift</b>		32 ft. 10 in.	10 m
<b>Max. Pressure</b>		42 psi	2.9 Bars
<b>Environmental Requirements</b>	<b>Temp. Range</b>	-4 to 140°F	-20 to 60°C
	<b>Max. Humidity</b>	90%	
<b>Power Cord Length</b>		4 ft. 11 in.	1.5 m
<b>Net Weight</b>		6.6 lb.	3 kg

# Package List

1 × Pump Body  
2 × Connectors

2 × Hose Clamps

# Product Diagram

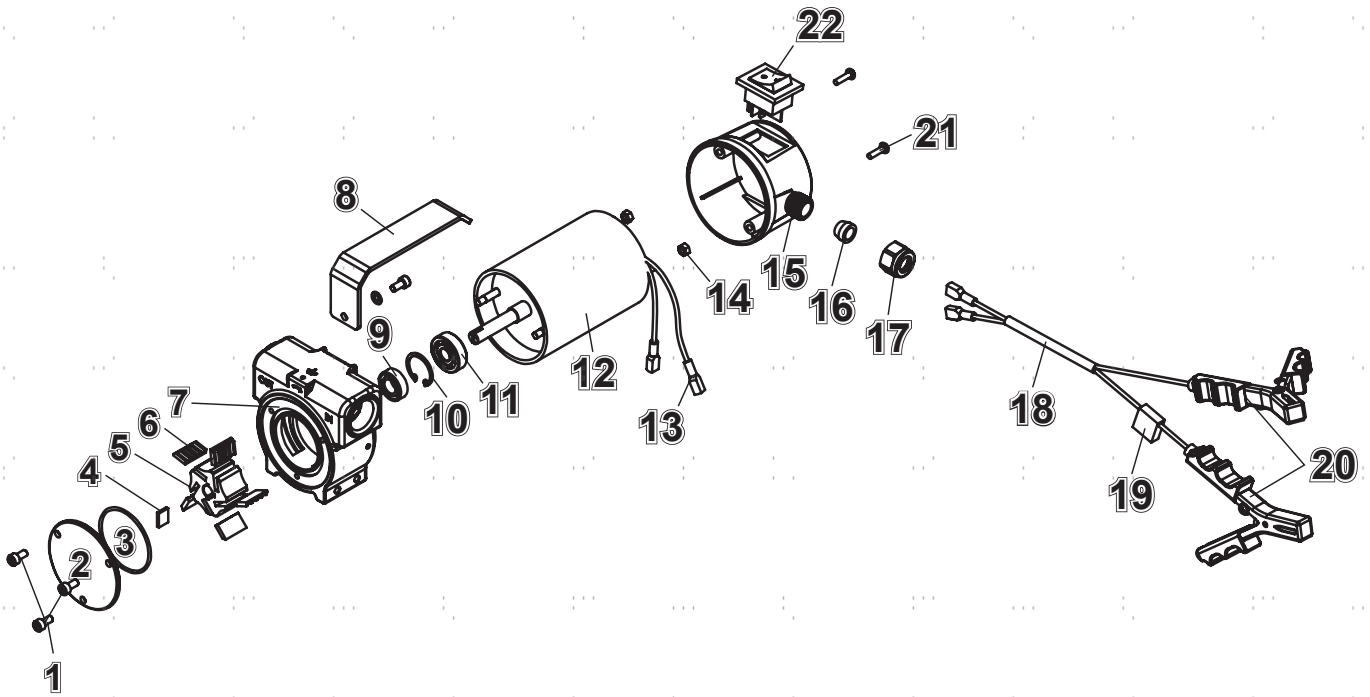

No.	Name	Qty.
1	M5×10 mm Bolts	8
2	Front Cover	1
3	O-Ring	1
4	Key	1
5	Rotor	1
6	Vanes	5
7	Pump Body	1
8	Handle	1
9	Seal	1
10	Bypass Valve	1
11	Bearings	2

No.	Name	Qty.
12	12V Motor	1
13	Power Cords	2
14	M5 Nuts	2
15	Terminal Board	1
16	Taper Ring	1
17	Compaction Nut	1
18	Power Cord	1
19	25A Fuse	1
20	Terminal Clamps	2
21	M4×15 mm Bolts	2
22	Power Switch	1

# Installation

1. Place the pump onto a stable horizontal surface. Apply tape to the threading of your hose or hose connectors. Wrap the tape snugly in the direction of the threading and leave the last 2 turns of the thread clear for easier installation.
2. Assemble your supply and discharge hoses according to their separate instructions and then screw their hose connectors into the inlet and outlet ports of the pump body (7) respectively.
3. Prepare a car battery or similar 12V DC power source within reach of the terminal clamps (20) on the power cord (18). Be sure to arrange the cord so that it will not create a tripping hazard or be not exposed to possible damage during use.

# Operation

1. Prepare your supply and destination tanks, making sure that both are securely grounded and your work area is well ventilated. Remove their covers or caps. For best results, position them so that both your hoses are as straight as possible.
2. Insert the nozzle of your discharge hose into the destination tank. Confirm that the lock and trigger aren't already activated.
3. Insert the strainer of your supply hose into your supply tank and allow it to sink into your fuel until it is completely submerged.
4. Connect the red terminal clamp (20) to the positive (+) terminal of your power source first. Connect the black terminal clamp to the negative (-) terminal.
5. Use the power switch (22) to start the pump.
6. Follow your discharge hose's instructions to start transferring the fuel. When your transfer is completed, use the power switch to turn off the pump.
7. Disconnect the black terminal clamp from the power source's negative terminal first. Disconnect the red terminal clamp from the position terminal.
8. Release any excess fuel in the discharge hose into either tank. Remove the nozzle and set it aside where it cannot spill excess fuel on any flammable substance.

# Maintenance

- Ensure that the pump is turned off and fully disconnected from power before undertaking any cleaning, repair, or other maintenance.
- Check the condition of this device before and after each use. Never use it if any part shows visible wear, damage, or any other sign of malfunction. Repair or replace damaged components with identical parts before further use.
- Always fully remove any excess fuel from its exterior surfaces after each use. Clean exterior surfaces with a soft damp cloth. Do not use caustic chemicals or harsh abrasives except on the clamps.
- Use steel wool on the clamps at least once a month to allow them to create strong electrical connections with your power source.
- Allow time for all components to dry completely before storing this device in a cool dry location away from direct sunlight and inaccessible to children.

# Troubleshooting

Potential Problems	Possible Solution(s)
The pump does not start.	Check the device's fuse.
	Check your electrical connections, adjusting or cleaning them as necessary.
	Check the condition of your power supply.
The pump works in the wrong direction.	Check that your hoses and connections were installed on the proper sides.
	Check your electrical connections, correcting the polarity (order of connections) as needed.
The pump works slowly or weakly.	Check that the hoses do not have any kinks, blockage, or sharp turns.
	Check that the strainer, nozzle, and their connections are undamaged and unblocked.
	Check the supply tank for anything in the fuel that might be obstructing the strainer.
	Check the hoses for any leaks.

# Disposal

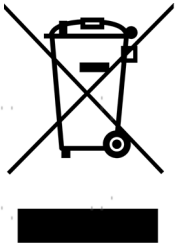

Electrical products should not be disposed of with household products. In the EU and UK, according to the European Directive 2012/19/EU for the disposal of electrical and electronic equipment and its implementation in national laws, used electrical products must be collected separately and disposed of at the collection points provided for this purpose. Locations in Canada and the US may have similar regulations. Contact your local authorities or dealer for disposal and recycling advice.

# Contact Us

Thank you for choosing our products! If you have any questions or comments, contact us at [help@cs-supportpro.com](mailto:help@cs-supportpro.com) and we'll resolve your issue ASAP!

For a .pdf copy of the latest version of these instructions, use the appropriate app on your smartphone to scan the QR code to the right.



